

# RE-25MB

## MODBUS CONVERTER FOR RE-25AR

### General

Modbus convertor converts the Ravel protocol to Modbus protocol with RS485 serial communication. This convertor normally used in integrating with equipments like SCADA, PLC's & BMS system.

### Features

- Gives full status of all detectors, outputs and inputs of Fire Alarm Control Panel.
- Two types of interrogation with Master & slave devices.
- Available as RS232 and RS485 Interface.

### Specification

Electrical Specification	
<i>Operating Voltage</i>	24 VDC
<i>Operating Temperature</i>	0°C to 49°C / 32 to 120°F.
<i>Relative Humidity</i>	93 ± 2% RH (non-condensing) at 32 ± 2° C/96 ± 3° F.
<i>Standby current</i>	0.1 Amps (max).
<i>Enclosure</i>	Epoxy Powder coated
<i>Communication Interface</i>	RS485 / RS232
<i>IP Rating</i>	IP50
Mechanical Specification	
<i>Size</i>	(120L X 110H X 60D) mm.
<i>Cable Entry</i>	3 X Ø 19mm Knockout in top of the cabinet.
<i>Weight</i>	0.5 Kgs.

## Dimensions

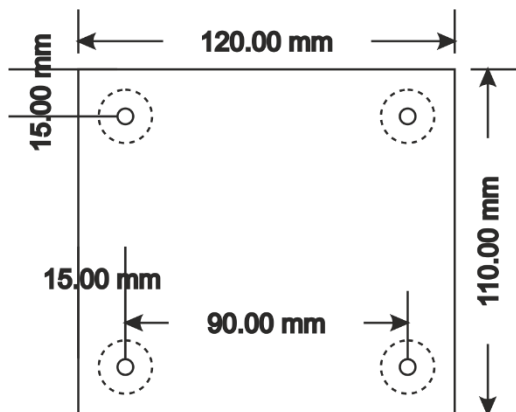

## Wiring Topology

RS 232 OUTPUT A B	RS 232 INPUT A B	RS 485 OUTPUT A B	RS 485 INPUT A B	24 VDC INPUT - +
-------------------------	------------------------	-------------------------	------------------------	------------------------

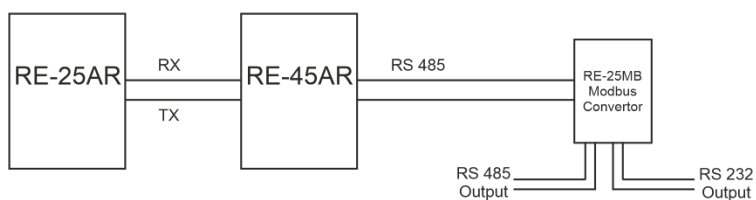

## Compatible Panel

Model	Description
RE-25AR	Agent Release Control Panel
RE-45AR	RS485 Interface Module

## Ordering Information

Model	Description
RE- 25MB	Modbus Converter for RE-25AR

### India

RAVEL ELECTRONICS PVT LTD.,  
150A, Electronics Industrial Estate,  
Perungudi, Chennai – 96, India.  
E-mail: [marketing@ravelfire.com](mailto:marketing@ravelfire.com); Web: [www.ravelfire.com](http://www.ravelfire.com)

### UAE

RAVEL DMCC,  
Unit No: G30, DMCC Business Center,  
Level No 13, AG Tower, Dubai, UAE.  
E-mail: [sales@raveldmcc.com](mailto:sales@raveldmcc.com)

### USA

RAVEL AMERICAS INC.,  
2855 NW 112<sup>th</sup> Ave ST#2 Miami,  
Doral, Florida 33172, USA.