

# RE-2554

## 4 IDC'S FIRE ALARM CONTROL PANEL

### General

This control panel is an UL Listed Microprocessor based conventional Fire Alarm Control Panel which has 4 Initiating Device Circuits. These control panels are designed to be used in small and medium sized commercial complexes, buildings, hotels, schools, and industrial establishments. They are compatible with conventional detectors, manual pull station and normally open dry contact devices.



### Special Features

- Switched Mode Power Supply.
- Modular Construction.
- Auto Resettable Fuse.
- Surge Protection for all Input and outputs.
- Battery polarity reversible protection.
- Surface Mount Technology.
- Over all current consumption is low.

### Features

- UL Listed and complies NFPA-72.
- Rugged CRCA sheet with powder coated finish.
- Operates on 110 - 220VAC 50 /60 Hz, AC mains power supply.
- 16x2 Dot Matrix LCD display.
- 4/8 Class B Style 'B ' or Style 'C' Initiating Device Circuit (IDC).
- All zones accept smoke detectors and normal open contact devices.
- Any zone can be configured as alarm or supervisory zone.
- 2 Class B Notification Appliance Circuits (NAC).
- NAC shall be programmed as silenceable or non-silenceable.
- Supervisory zone shall be latching or resettable.
- Standby (battery) backup 24VDC power supply with built in charger.
- Error free Fire / Fault status in unambiguous colored LED indication.
- System ON indication.
- Main & Standby status with audible and visual indication.
- Battery low visual warning with audible tone.
- Form C relays for fire, fault and supervisory.
- Resettable / Steady 24VDC Output.
- RS 485 Communication facility (Optional).
- Lamp test facility.
- All field wiring circuits are power limited except 110-220VAC and battery.
- All field wiring circuits are supervised.
- Walk test facility.
- Zone isolation facility with loop voltage cut off.
- Earth fault annunciation facility at 0 ohms.
- AC low voltage cutoff.
- Programmable AC loss delay.
- Programmable alarm verification.
- Programmable trouble reminder.

## Specification

Electrical Specification	
<b>Primary Power</b>	110 - 220VAC + 10% -15%, 60/50 Hz, 100W.
<b>Standby Power</b>	24VDC (2 Nos of 12V, 12Ah Sealed Lead acid battery). Quiescent current: 120mA
<b>Operating Condition</b>	Operating temperature: 0 – 49° C / 32 – 120° F Storage Temperature: 0 ° C to 60 ° C Relative humidity: 93 ± 2% RH (non-condensing) at 32 ± 2° C / 90 ± 3° F
<b>Charging Circuit</b>	Charging voltage: 28 V, ± 2% nominal Charging current: 800mA (max)
<b>Notification Appliance Circuits</b>	Quantity: 2 Wiring style: Class B, Style Y Operating Nominal Voltage: 24 VDC Nominal Current: 1.2A (0.6A per circuit) Line drop: 1.8V EOL resistor: 3K9, ½ watt
<b>DC Output</b>	Supervised 24VDC regulated, 300mA Max.
<b>Relays</b>	Type: Form C No of Relays: 3 Relay contact rating: 2A @ 30 VDC, 0.5A @ 125 VAC Power factor: 1.0
<b>Initiating Device Circuits</b>	Quantity: 4 Wiring style: Class B, Style B/C Normal operating voltage: 14 – 21 VDC Alarm current: 15 – 30 mA Short circuit current: 45 mA (max) Loop resistance: 100 Ω (max) EOL Resistor: 3K9, ½ watt Standby current: 7 mA (2 mA for detectors)
Mechanical Specification	
<b>Dimensions</b>	(440 W x 340 H x 120 D) mm
<b>Color</b>	White / Red
<b>Construction</b>	18 Gauge (1.22mm) CRCA sheet with powder-coated finish.
<b>IP Rating</b>	IP50
<b>Cable Entry</b>	11xØ19mm Knockout on top of the cabinet. 10xØ22.25mm Knockout on top of the cabinet.

## Dimensions

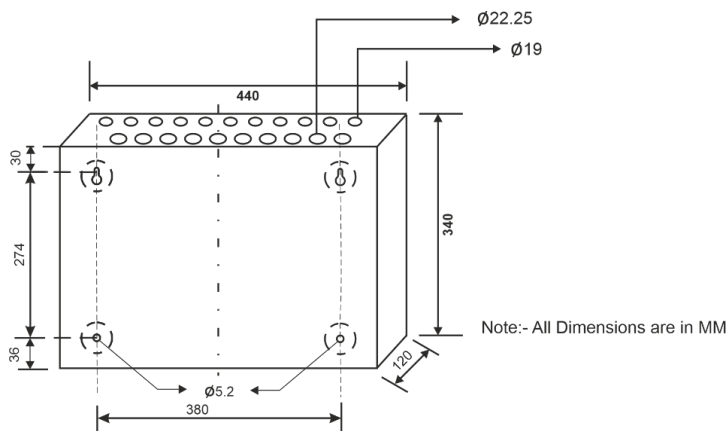

# Wiring Configuration

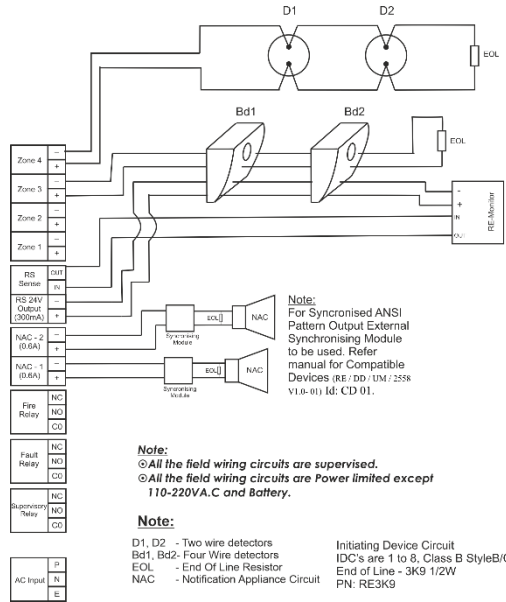

# Compatible Devices

Models	Description
RE-316S-2L	Conventional Photoelectric Smoke detector with base.
RE-316H-2L	Conventional Heat detector with base.
RE-316SH-2L	Conventional Multi sensor detector with base
RE-314	Common base for above
RE-716MR	Manual Call Point
RE-24CS	Conventional Sounder
RE-25SS	Conventional Sounder cum strobe
RE-716SO	UL Listed Conventional Sounder
RE-716SS	UL Listed Conventional Sounder cum Strobe
RE-716P1T	UL Listed Single Action Manual Pull station
RE-716P1TLP(R)	UL Listed Dual Action Manual Pull Station
RE-Monitor	24VDC Output for Monitor Module
RE-3K9 (UL Listed)	End of Line Resistor

# Ordering Information

Model	Zones
RE-2554	Conventional 4 IDC's Fire Alarm Control Panel.

Note:

W- White Colour

R – Red Colour

## India

RAVEL ELECTRONICS PVT LTD.,  
 150A, Electronics Industrial Estate,  
 Perungudi, Chennai – 96, India.  
 E-mail: sales@ravelfire.com; Web: www.ravelfire.com

## UAE

RAVEL DMCC,  
 Unit No: G30, DMCC Business Center,  
 Level No 13, AG Tower, Dubai, UAE.  
 E-mail: sales@raveldmcc.com

## USA

RAVEL AMERICAS INC.,  
 2855 NW 112<sup>th</sup> Ave ST#2 Miami,  
 Doral, Florida 33172, USA.  
 E-mail: sales.us@ravelfire.com